

Optical Shutters

Features

- Mounted and unmounted design options
- Maximum switching speed performance
- Unlimited OEM sizes and shapes
- Fifty percent duty cycle operation
- Portable and lightweight
- No mechanical motion

Applications

- Three-dimensional imaging
- Optical instrumentation
- Telecommunications
- Holography
- Printing

Benefits

- Meets your application-specific requirements
- Silent, vibration-free, low-voltage operation
- Solid state construction
- Affordably priced

Description

An Optical Shutter is a two-state device used to rapidly open and close a light path (from lens to film, for example). Optical Shutters are typically used to control the amount of time that a light-sensitive material is exposed to optical radiation. Figure 1 provides a conceptual illustration of the function of an Optical Shutter.

Boulder Nonlinear Systems (BNS) manufactures and sells liquid crystal based Optical Shutters for applications requiring active timing control of beam transmittance. Key features of our Optical Shutters include high-speed binary operation, high purity linear polarized output, and maximum extinction ratio performance. Since these devices are solid state – undesirable mechanical motion, associated noise, and vibration problems are eliminated.

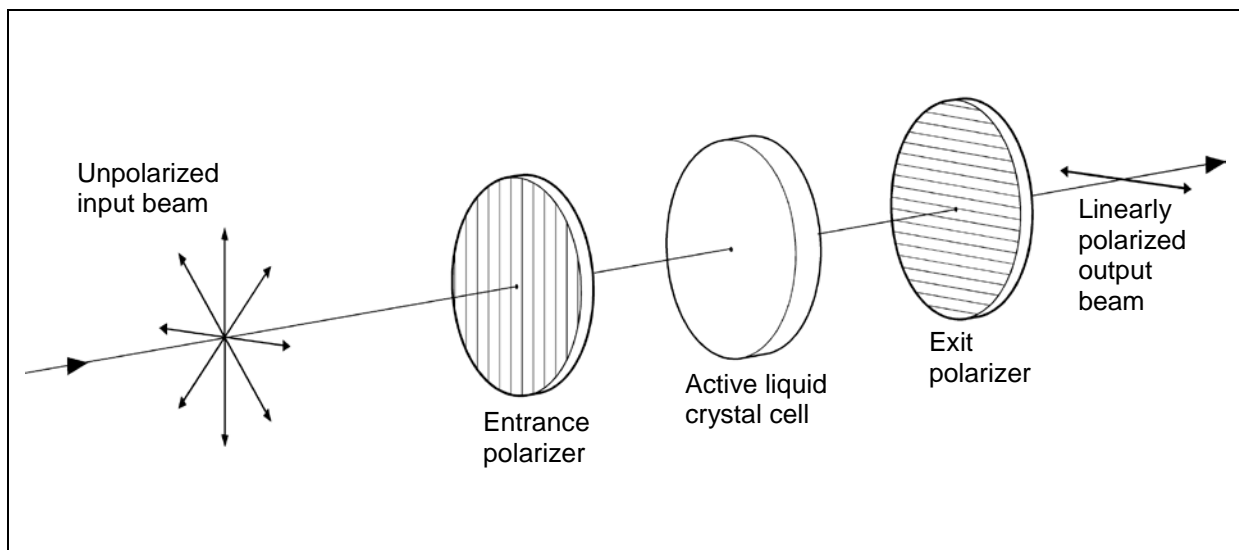

Figure 1 ~ Conceptual illustration of an Optical Shutter function.

MS Series Optical Shutters

Maximum switching speed performance

The MS Series offers a significant performance advantage in Optical Shutter applications demanding the fastest optical response times, typically ranging from 15 – 150 μ s. Attractive for their high switching speeds, MS Optical Shutters require a dc-balanced ac drive signal, typically resulting in 50% duty cycle operation. Minimum drive voltage levels are required; as low as ± 5 V ac is sufficient for most applications.

Device Construction

Figure 2 below provides a typical Optical Shutter cross section.

MS Series Optical Shutters begin with polished, optically flat windows. After deposition of a transparent conductive coating layer (indium-tin oxide or ITO, typically) these window substrates are then evenly covered with a polymer layer,

which is then rubbed or buffed, forming tiny microgrooves in the polymer layer. These microgrooves provide the alignment directionality critical in liquid crystal device production.

The coated and buffed windows are then spaced a few microns apart. The cavity between substrates is now filled with liquid crystal material and sealed.

High extinction linear polarizers are crossed, and then laminated between glass substrates. External glass surfaces are usually coated with a broadband antireflection coating, to maximize transmittance. With this crossed polarizer orientation, MS Series Optical Shutters exhibit full optical transmittance at the negative voltage state. Minimum transmission occurs at the positive voltage level, as specified with your device.

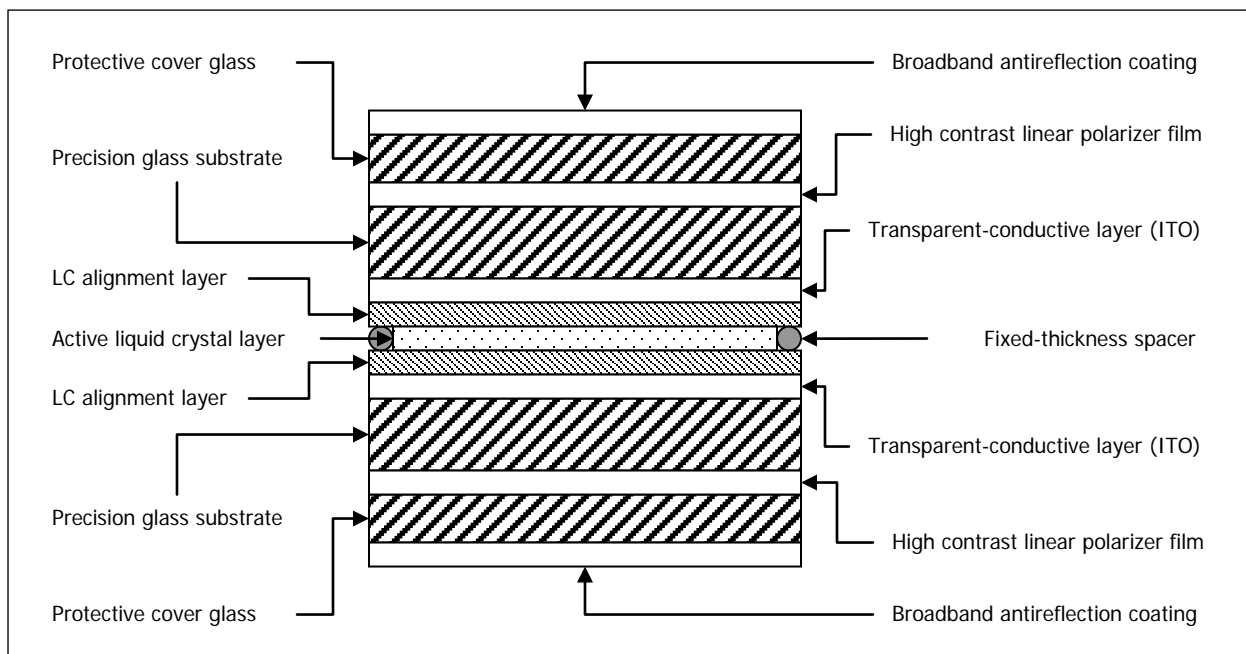
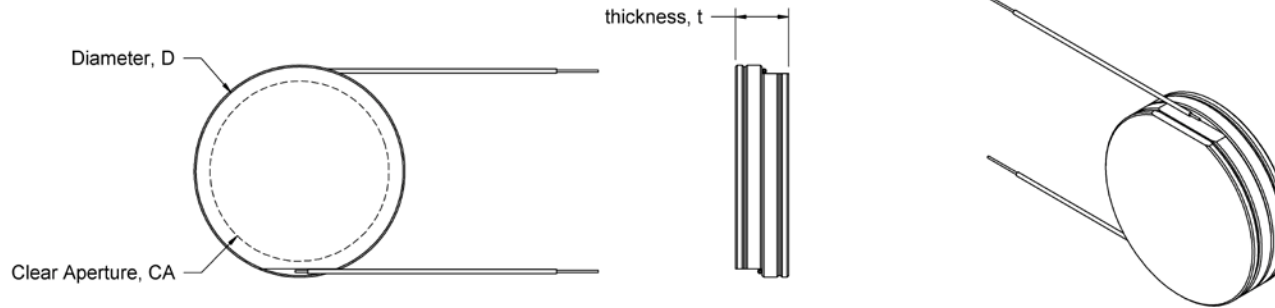

Figure 2 ~ Cross sectional representation of an MS Series Optical Shutter.

NOTES:

- 1) All dimensions in millimeters.
- 2) Transmission axes of linear polarizers are crossed relative to one another.
- 3) External surfaces antireflection coated for 400 – 700 nm, R(abs) ≤ 1% per surface.
- 4) Flying wire leads are color-coded. Connect black to ground, red to drive signal.
Wires are 30 AWG, stranded, and insulated. Wire lead length 180 mm (± 10 mm) with 5 mm (± 1 mm) stripped on free ends.
- 5) Cosmetic surface quality 40 – 20 scratch dig.
- 6) Standard grade, noncrystalline, synthetic fused silica substrate material.
Corning® HPFS® 7980, homogeneity Grade C or equivalent.
- 7) Substrate edges beveled to ≤ 0.25 mm face width at 45° ± 5°.

ZONE		REV.	REVISIONS	DATE	APPROVED
			DESCRIPTION		



MS Series Optical Shutters		
Standard Dimensions		
Clear Aperture, CA	Diameter, D	Thickness, t
minimum	± 0.2	
15.0	22.0	9.6
25.0	34.0	14.0
50.0	60.0	24.4

		DIMENSIONS ARE IN MM EXCEPT WHERE OTHERWISE SPECIFIED.			NAME	DATE
		TOLERANCES:			R. Martin	01/23/04
		ANGULAR: MACH ±				
		BEND ±				
		ONE PLACE DECIMAL ±0.2				
		TWO PLACE DECIMAL ±0.1				
		MATERIAL				

		FINISH				

NEXT ASSY	USED ON			COMMENTS:		
APPLICATION		NOT TO SCALE				

BOULDER NONLINEAR SYSTEMS, INC.		
Optical Shutter, MS Series, Standard		
SIZE	DWG. NO.	REV.
A		3
WEIGHT:		SHEET 1 OF 1

Figure 3 ~ Top level assembly drawing for standard MS Series Optical Shutters.

Optical Shutters

MS Series

Specifications (Preliminary)

Clear Aperture		5 – 95 mm	
Wavelength Range		425 – 675 nm	
Pixel Count		1 – 256	
Pixel Pitch		5 μ m (minimum)	
Open State Transmission (unpolarized)		30%	
Contrast Ratio		<i>Minimum</i> 100:1	<i>Average</i> 200:1
Response Time	open to closed (90 – 10%)	<i>Minimum</i> 15 μ s	<i>Maximum</i> 200 μ s
	closed to open (10 – 90%)		
Driver Requirement		\pm 5 volts	
Duty Cycle		50%	
Switching Frequency¹		5 kHz (maximum)	
Operating Temperature		20 to 30° C	
Storage Temperature		0 to 60° C	

1. At room temperature, \pm 5 V ac.

Above specifications are subject to change without notice. Please contact Boulder Nonlinear Systems for additional updates.

Company Profile

Boulder Nonlinear Systems, Inc. (BNS) is an innovative technology company specializing in dynamic liquid crystal polarization control solutions for both laser-based and imaging systems. Company strengths in scientific research and development are leveraged into OEM and standard product offerings targeted for astronomy, biomedical, defense, microscopy, optical computing, optical storage, and telecommunications applications.

For additional product and company information, please contact:

Boulder Nonlinear Systems, Inc.
450 Courtney Way
Lafayette, CO 80026 – 8878
USA

Telephone: (303) 604 – 0077
Toll free: (866) 466 – 0506
Fax: (303) 604 – 0066
E-mail: sales@bnonlinear.com
Website: www.bnonlinear.com